

Specifications for Industrial Concrete Cobbles 60 mm Thick Shotblasted and coated finish

Supply of Solid Industrial Grade Concrete Cobbles of VYARA make, in Shotblasted and coated finish

- in colours specified by the architects.
- using UV resistant colour pigments from Lanxess.
- wear resistant colour coordinated aggregates.
- with two coats of transparent UV resistant acrylic paint.
- Size 97*97*60 mm thick. Nominal size of 100mm *100mm.

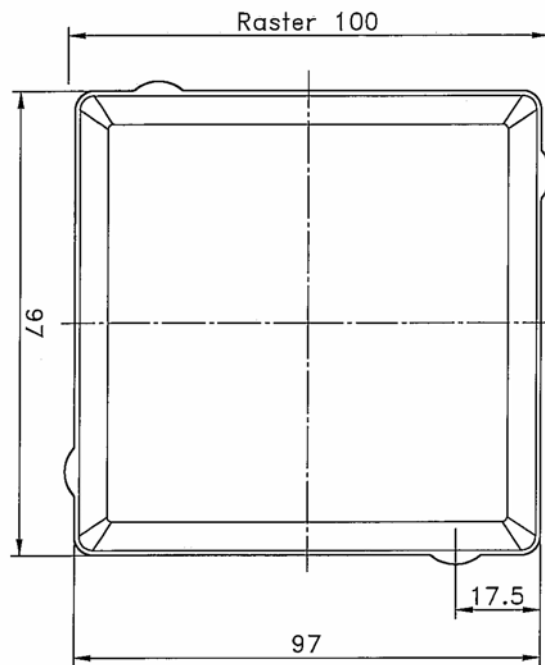

Sr.	Parameters	Minimum Requirements
1.	Percentage Water Absorption	Average not over 4.5%
2.	Compressive strength	Average not less than 250 Kg/cm ²
3.	Tensile Splitting Strength (as per EN 1338)	Average not less than 3.6Mpa
4.	Average wear in Thickness- Abrasion	Conforming to Grade 'H' of EN 1338
5.	Tolerance in size (length + breadth)	± 1.5mm
6.	Thickness of wearing layer	Not less than 5mm
7.	Tolerance in Thickness of block	± 3mm
8.	Colours	UV Light resistant fast colours from Lanxess only to be used.

- The blocks must be manufactured on Vibropress type machine only. The manufacturer must demonstrate feeding of material into the machines by automatic batching plants with capacity of min 30 m³/hr.
- The manufacturing company must be an ISO 9001:2008 certified Company or should have equivalent quality management systems in place to ensure quality product.
- The blocks will be made using wear resistant materials in the face mix as specified by the architects.
- The colours of the blocks (wearing layer) will be as selected by the architects.
- The blocks must be cured in controlled environment to ensure efflorescence free material.
- The manufacturer must have in house testing laboratory to carry out all testing including Compressive strength testing, Water absorption, abrasion resistance etc.